

# MWR-8 INSTALLATION PROCEDURE: (3 STEPS)

## 1 DIAGRAM OF CONNECTIONS:

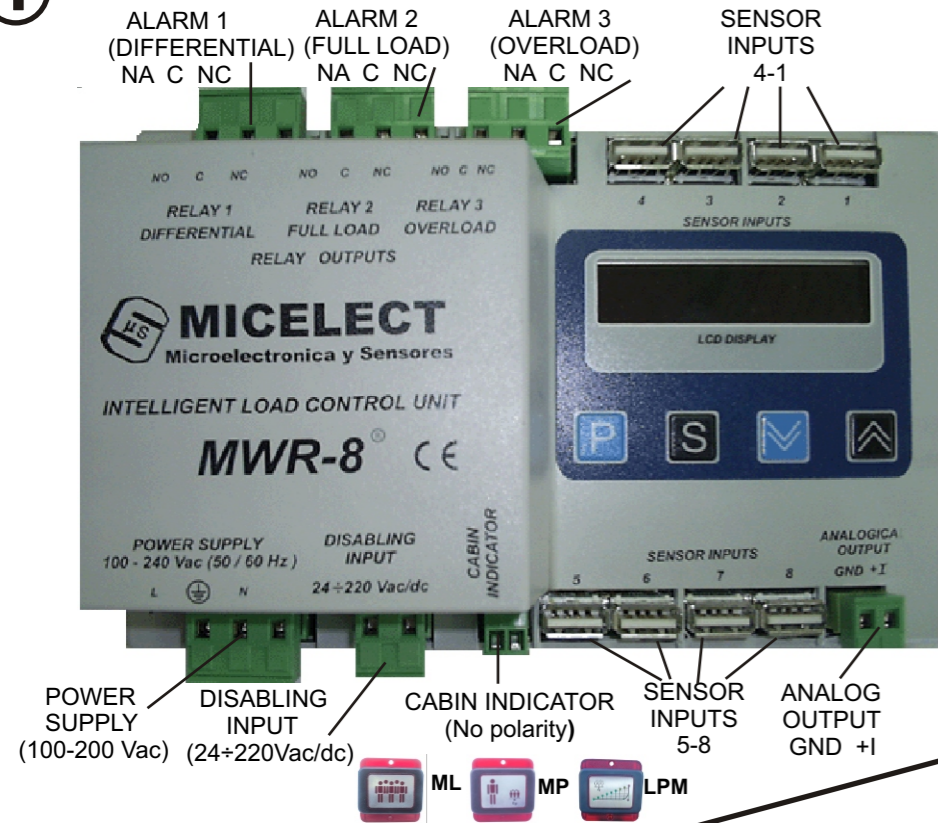

## 2 KEYS AND FIGURES:

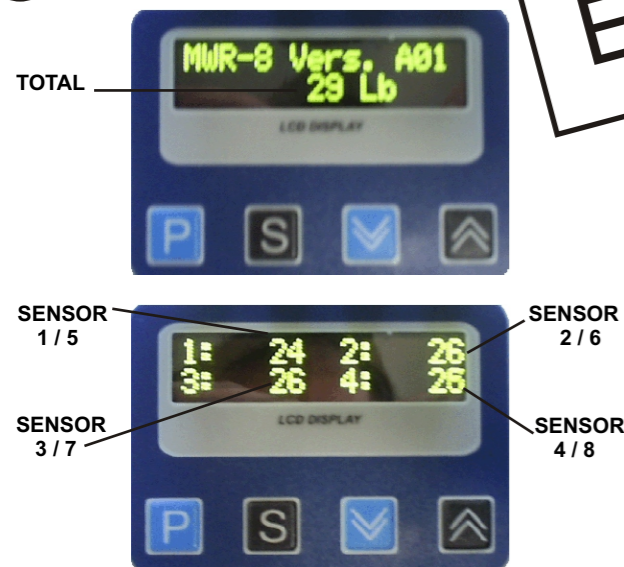

**Note:** The display remains switched off after 10 minutes of normal operation. Pressing any key the display value is visualized again.

### PROGRAMMING KEY "P"

Allows to go through the different menus in order to perform the settings and to introduce the lift parameters. Once introduced, by pressing the "P" key, parameters are saved in memory.

### EXIT KEY "S"

Allows to leave the menus without saving data in memory.

### DOWN KEY "V" / UP KEY "A"

In the menus, allows the user to decrease or increase the parameter values.

In the weighing mode, allows to scroll between these different views:

- Channels 1, 2, 3 and 4.
- Channels 5, 6, 7 and 8.
- Total weight.

ENGLISH

## 3 DISABLING OR BLOCKING VOLTAGE:

The disabling signal range is ( 24-220 V ac/dc);

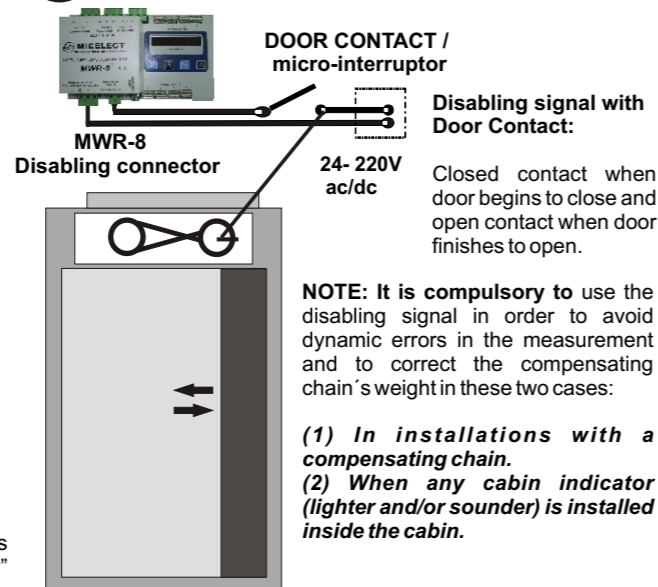

**NOTE: It is compulsory to use the disabling signal in order to avoid dynamic errors in the measurement and to correct the compensating chain's weight in these two cases:**

- (1) In installations with a compensating chain.
- (2) When any cabin indicator (lighter and/or sounder) is installed inside the cabin.

**NOTE: The MWR-8 must continuously receive a blocking signal during all the time the lift is travelling, from the moment the doors are closing until the cabin gets on floor and the lift opens doors again. NOTE: Continuously. (Voltage 24-220Vac/dc)**

The display value will keep frozen after receiving this signal.

Connect the disabling or blocking wires using for example, a door contact micro fed with voltage once the door begins to close.



## ALARM CONNECTING CODE:

NA.....NO=Normally open.  
C.....C=Common.  
NC.....NC=Normally closed.

Relays electrical ratings:  
250Vdc / 3 A

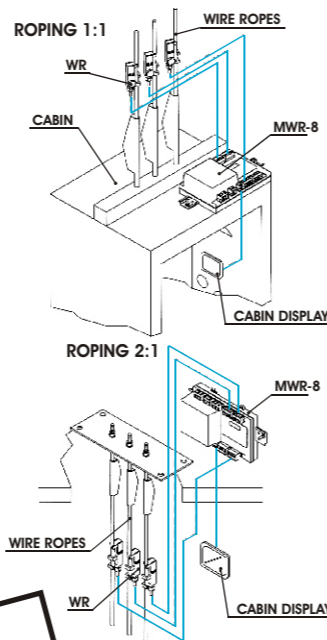

# MWR-8 PROGRAMMING PROCEDURE: (8 STEPS)

Press the "P" key to begin the programming procedure.

## 1 MEASURING UNITS: "Unit Selection"

"KG" = Measurement in kilograms.  
"LB" = Measurement in pounds.

## 2 NUMBER OF SENSORS: "Number of WR?"

We must introduce the number of WR sensors installed.

## 3 ZERO CALIBRATION: "Zero Setup"

Make the zero setting with empty cabin. Pressing the "P" key the equipment begins to flicker for 15 seconds to permit the installer to leave the cabin totally empty.

## 4 SENSOR CONFIGURATION: "Calibr.Method?"

### \*\* (Automatic) "wire diameter"

The diameter in millimetres of the wire ropes has to be introduced from 8 to 16 and 20 mm.

### \*\* (Manual) "Well-Known weight"

Using this configuration a known weight has to be used to set up the sensor. Place a known weight, which must be - at least - half the useful load. Introduce by means of the keys the weight in Kg/Lb. Placed inside the cabin and perform the weight setting.

## 5 COMPENSATING CHAIN WEIGHT: "Compens. Chain?"

If our installation has a compensating chain we must select "YES".  
If our installation has not got a compensating chain we must select "NO".

**NOTE:** If we select "YES" we must be sure that the disabling connector is connected following the diagram of the point 3 of the installation procedure.  
**Closed contact when door begins to close and open contact when door finishes to open.**

**Note:** Contact with a voltage range from 24 to 220 Vac/dc, during all the time lift is travelling. **Note: Continuously**

## 6 CABIN INDICATOR: "Car Indicator?"

"NO" = No indicator installed inside the cabin.  
"PROG" = MICELECT progressive models (MP or LPM)  
"BASI" = MICELECT basic indicator ML model or any lighter-sounder system powered by 24Vdc

## 7 ANALOGICAL OUTPUT: "Analog Output?"

"NO" = Analogical output not active.  
"0-20" = Linear signal (0-20 mA).  
"4-20" = Linear signal (4-20 mA).  
"0-24" = Linear signal (0-24 mA).

**NOTE:** The analogical output provides a lineal signal.  
The maximum value (20/24 mA) corresponds to the value in (Lbs) of alarm 3.

## 8 ALARM VALUES:

The electronic control unit has three alarms.  
**Alarm 1** : It is assigned to the signal for inequality between the tension of the ropes. The percentage of inequality between the ropes must be chosen, from 5% to 40%; that is, 5% implies that if there is a difference in 5% between the tension of the ropes, the alarm will activate itself  
**Alarm 2** : It can be assigned to FULL LOAD. 80% Total Load.  
**Alarm 3** : It is always assigned to OVERLOAD. 100% Total Load.

## ERROR CODES:

- ERR1 ... No saved Data.
- ERR2 ... Overload.
- ERR3 ... Power Supply Low.
- ERR4 ... Negative Known weight.
- ERR5 ... (Well-Known) weight Low.
- ERR6 ... (Well-Known) weight High.
- ERR7 ... Differential rope tension is incorrect.

## SOLUTIONS:

- ERR1 ... Make again the settings.
- ERR2 ... Weight > 9999 Kg/Lb.
- ERR3 ... Check the Power Supply.
- ERR4 ... Some possible "hooks"/ wrong wiring sensor. Check sensor colour code.
- ERR5 ... See part 3. Programming procedure "Well-Known weight" (Correct useful load).
- ERR6 ... See part 3. Programming procedure "Well-Known weight" (Correct useful load).
- ERR7 ... Readjustment of rope tension necessary.

MICELECT S.L. C/OTOÑO, 23 Parque Industrial "Las Monjas" 28850 Torrejón de Ardoz MADRID (SPAIN)

Tel: +34 91 660 03 47 Fax: +34 91 660 04 73 e-mail: [micelect@micelect.com](mailto:micelect@micelect.com) Internet: <http://www.micelect.com>

