

LM3D INSTALLATION PROCEDURE: (3 STEPS)

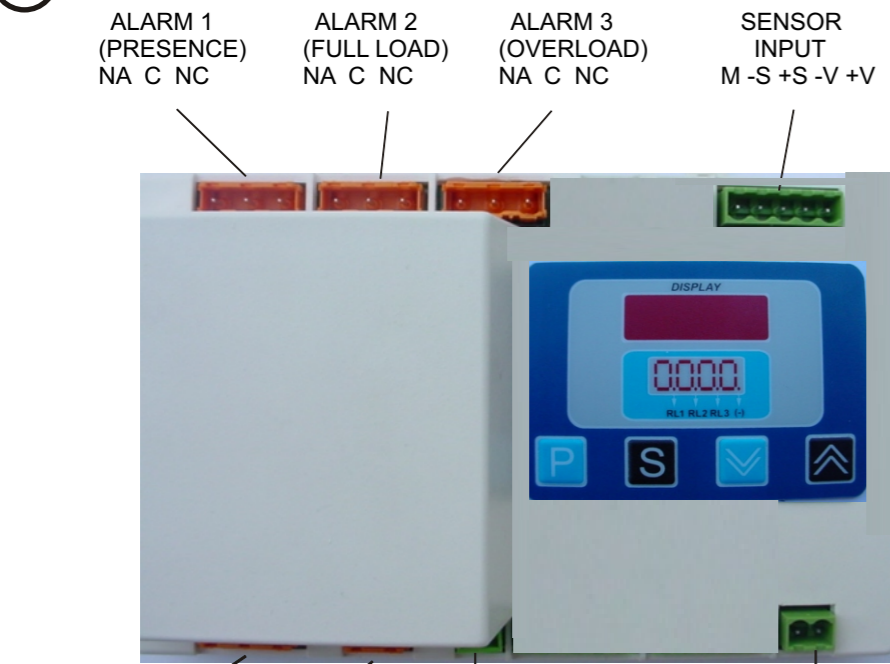

1 DIAGRAM OF CONNECTIONS:



SENSOR CONNECTING CODE:
 M.....MESH
 -S.....- Signal..YELLOW.
 +S.....+ Signal..GREEN.
 -V.....- Vdc.....BLACK.
 +V.....+ Vdc.....RED.

ALARM CONNECTING CODE:
 NA.....NO=Normally open.
 C.....C=Common.
 NC.....NC=Normally closed.

Relays electrical ratings:
 250Vdc / 3 A

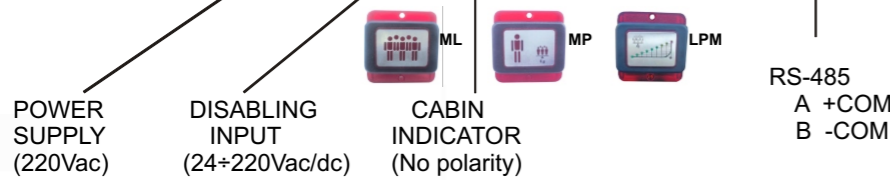

2 KEYS AND FIGURES:

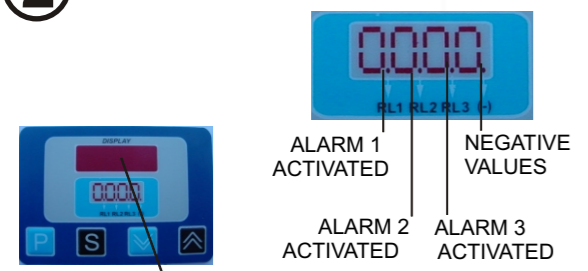

Note: The display remains switched off after 5 minutes of normal operation. Pressing any key the display value is visualised again.

3 DISABLING OR BLOCKING VOLTAGE:

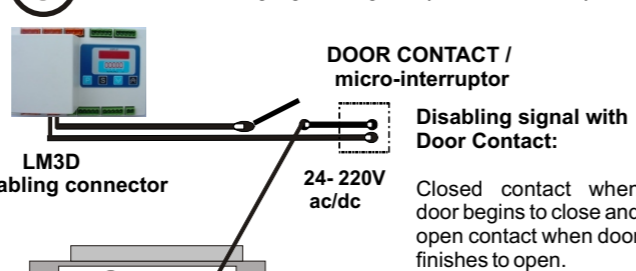

NOTE: It is compulsory to use the disabling signal in order to avoid dynamic errors in the measurement and to correct the compensating chain's weight in these two cases:

- (1) In installations with a compensating chain.
- (2) When any cabin indicator (lighter and/or sounder) is installed inside the cabin.

The LM3D must continuously receive a blocking signal during all the time the lift is travelling, from the moment the doors are closing until the cabin gets on floor and the lift opens doors again.

NOTE: Continuously. (Voltage 24-220 Vac/dc)

The display value will keep freezed after receiving this signal.

Connect the disabling or blocking wires using for example a (door contact micro) fed with voltage once the door begins to close.

PROGRAMMING KEY "P"
 This key allows to go through the different menus in order to perform the settings and to introduce the lift parameters. Once introduced, by pressing the "P" key parameters are saved in eeprom (a non volatile memory to save data in case of power failure.)

EXIT KEY "S"
 It allows to leave the menus without saving data in eeprom. In the alarm menus, we go from one alarm to another without going through their parameters. In the measuring mode, keeping this key pressed on enables the visualisation of the installation's real weight without the compensating chain correction.

DOWN KEY "V"
 This key enables the user to decrease the parameter values in each menu. It has two speeds; one by one or, if pressed on, twenty by twenty.

UP KEY "A"
 This key enables the user to increase the parameter values in each menu. It has two speeds; one by one or, if pressed on, twenty by twenty.

LM3D PROGRAMMING PROCEDURE: (7 STEPS)



Press the "P" key during 3 seconds to begin the programming procedure.

1 ZERO CALIBRATION: "TARE"
 Make the zero setting with empty cabin selecting "YES". It is recommended to jump before inside the cabin in order to avoid any possible cabin "hooks" on the guide rails. After that, pressing the "P" key the equipment begins to flicker for 15 seconds to permit the installer to leave the cabin totally empty.

2 SENSOR CONFIGURATION:
 Depending on the selected option the setting procedure will be performed automatically or manually by means of a well-known weight.

**** LMC: (Automatic).** "LMC" wire rope sensor.
DIAMETER: the diameter in millimetres of the wire ropes has to be introduced from 6.0 to 16.0 mm.

**** VR: (Automatic).** Individual wire rope sensors (WR).
DIAMETER: dv. the diameter in millimetres of the wire ropes has to be introduced, from 8 to 16 and 20 mm.

**** UNIT:** nv. the number of WR sensors installed on the wire ropes must be introduced, from 1 to 8 (every wire rope must have one sensor installed.)

**** CCP: (Well-Known-weight)** (Bed frame sensor)
WEIGHT: a known weight has to be used to set up this kind of sensor, **place a known weight, which must be - at least - half the useful load.** Introduce by means of the keys the weight in KG. placed inside the cabin and perform the weight setting.

**** SENS:(Automatic).** Sensor sensitivity
 First, introduce the maximum capacity of the sensor in use (from 1 to 9999 Kg), press "P" and then introduce the sensitivity (from 0.5 mV/V to 3.0 mV/V).

**** CAB: (Automatic).** Cab 800 sensors.
UNIT: the number of pieces installed must be introduced. (4-6-8)
 All sensors or the sum of (dummies + sensors)

3 NUMBER OF PEOPLE:
 Select the maximum number of people inside the cabin, between 2 and 30. All the alarm values will be automatically assigned. The factory alarm 1 value will be 9999, although all these alarm values can be modified manually as shown on point 5.

4 TYPE OF ELEVATOR:
 Select if the elevator is a 1:1 direct traction system or a pulley system 2:1.

5 ALARM VALUES:
 The electronic control unit has three alarms:
 Alarm 3 (AL3) : It is always assigned to OVERLOAD (100% Load.)
 Alarm 2 (AL2) : It can be assigned to FULL LOAD (80% Load.)
 Alarm 1 (AL1) : It can be assigned to ANTINUISANCE.

6 COMPENSATING CHAIN WEIGHT: "CHAI"
 If our installation has a compensating chain we must select "YES". If our installation has not got a compensating chain we must select "NO".
NOTE: If we select "YES" we must be sure that the disabling connector is connected following the diagram of the point 3 of the installation procedure.
 Closed contact when door begins to close and open contact when door finishes to open.
Note: Contact with a voltage range from 24 to 220 Vac/dc, during all the time lift is travelling. **Note: Continuously.**

7 CABIN INDICATOR: "INDI"
 "NO" = No indicator installed inside the cabin.
 "PROG"=MICELECT progressive models (MP or LPM).
 "BASI"=MICELECT basic indicator ML model or any lighter-sounder system powered by 24Vdc.

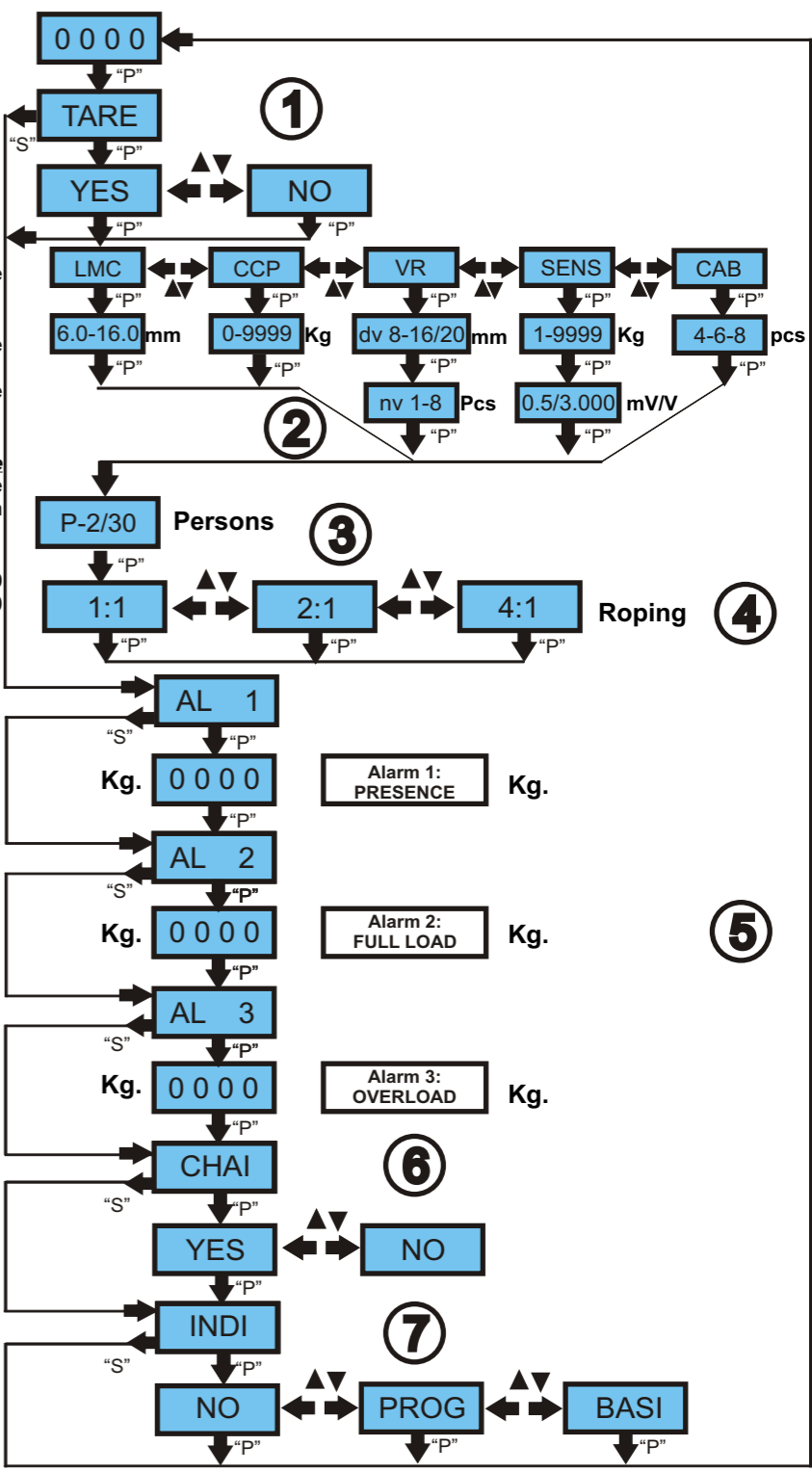

ERROR CODES: SOLUTIONS:

ERR1....No saved Data.
ERR2....Overload.
ERR3....Power Supply Low.
ERR4....Negative Known weight.
ERR5....Known weight Low/High

ERR1....Make again the settings.
ERR2....Useful Load > 9999 Kg.
ERR3....Check the Power Supply.
ERR4....Some possible "Hooks" / Wrong wiring Sensor. connection. Check sensor colour code.
ERR5....See part 2 Programming procedure CCP model (Correct Useful Load).

MICELECT S.L. C/OTOÑO, 23 Parque Industrial "Las Monjas" 28850 Torrejón de Ardoz MADRID (SPAIN)
 Tel: +34 91 660 03 47 Fax: +34 91 660 04 73 e-mail: micelect@micelect.com Internet: <http://www.micelect.com>

