

# ILC3 INSTALLATION PROCEDURE: (4 STEPS)



## 1 INSTALLATION ON THE ROPES:

The best method to install the ILC3 is to place it around (1,5 - 2) metres above the shackles, where the ropes are parallel, and close it slightly; then bring it down as close as possible to the rope hitch and close the central clamp as tight as possible.

**Note:** There is no minimum distance from the sensor to the shackles as long as, all the ropes are held by the central clamp and they all rest on the top and bottom cylinders as parallel as possible.

Both screws must be fully tightened.

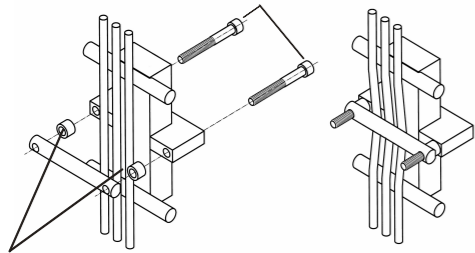

Cylinder spacers limiting the tightness.

They are marked with the diameter of the wire ropes in millimetres.

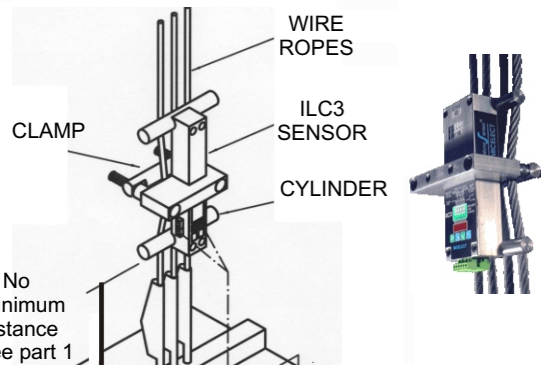

No minimum distance see part 1

## 2 CONNECTIONS:



### COLOUR CODE:

+ Vdc.....	RED.	(+24 / +48)
- Vdc.....	BLACK.	
DISABLING.....	BLUE.	(24 - 220 Vac/dc)
DISABLING.....	BLUE-RED.	(24 - 220 Vac/dc)
RELAY 1.....	GREY.	
RELAY 1.....	GREY-BROWN.	
RELAY 2.....	WHITE.	
RELAY 2.....	BROWN.	
ANALOGICAL OUTPUT (+).....	GREEN.	
ANALOGICAL OUTPUT (-).....	YELLOW.	
RELAY 3.....	PINK.	
RELAY 3.....	VIOLET.	
GROUND.....	ORANGE.	

**NOTE:** Relays electrical ratings: 250Vac/ 3 A Resistive.

## 3 DISABLING OR BLOCKING VOLTAGE:

The disabling signal range is ( 24-220 V ac/dc);

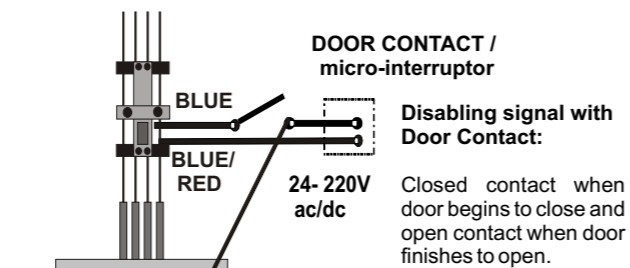

Disabling signal with Door Contact:

Closed contact when door begins to close and open contact when door finishes to open.

**NOTE:** It is compulsory to use the disabling signal in order to avoid dynamic errors in the measurement and to correct the compensating chain's weight in these two cases:

- (1) In installations with a compensating chain.
- (2) When any cabin indicator (lighter and/or sounder) is installed inside the cabin.

The ILC3 must continuously receive a blocking signal during all the time the lift is travelling, from the moment the doors are closing until the cabin gets on floor and the lift opens doors again.

**NOTE:** Continuously. (Voltage 24-220Vac/dc)

The display value will keep frozen after receiving this signal.

Connect the disabling or blocking wires (BLUE) and (BLUE-RED) using for example a (door contact micro) fed with voltage once the door begins to close.

## 4 KEYS AND FIGURES:

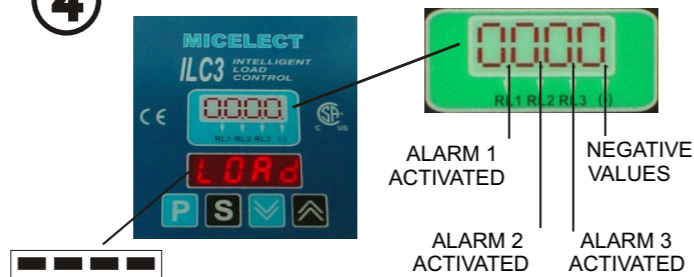

**Note:** The display remains switched off after 5 minutes of normal operation. Pressing any key the display value is visualised again.

### PROGRAMMING KEY "P"

This key allows to go through the different menus in order to perform the settings and to introduce the lift parameters. Once introduced, by pressing the "P" key parameters are saved in eeprom ( a non volatile memory to save data in case of power failure.)

### EXIT KEY "S"

It allows to leave the menus without saving data in eeprom. In the alarm menus, we go from one alarm to another without going through their parameters. In the measuring mode, keeping this key pressed on enables the visualisation of the installation's real weight without the compensating chain correction.

### DOWN KEY "▼"

This key enables the user to decrease the parameter values in each menu. It has two speeds; one by one or, if pressed on, twenty by twenty.

### UP KEY "▲"

This key enables the user to increase the parameter values in each menu. It has two speeds; one by one or, if pressed on, twenty by twenty.

# ILC3 PROGRAMMING PROCEDURE: (6 STEPS)



(Press the "P" key during 3 seconds to begin the programming procedure.)

## 1 MEASURING UNITS: "KG" / "LB"

"KG" = Measurement in kilograms.  
"LB" = Measurement in pounds.

## 2 ALARM VALUES: "RELY"

The ILC3 has three alarms that can be configured by HIGH or by LOW.

**HIGH=H**= Relay normally open up to the programmed value, above this value close contact.  
**LOW=L**= Relay normally closed up to the programmed value, above this value open contact.

**Alarm 3 (RL3)** : It is always assigned to **OVERLOAD. 100% Total Load.**

**Alarm 2 (RL2)** : It can be assigned to **FULL LOAD. 80% Total Load.**

**Alarm 1 (RL1)** : It can be assigned to **PRESENCE.**

## 3 ZERO ADJUSTMENT: "TAR"

Make the zero setting with empty cabin. It is recommended to jump before inside the cabin in order to avoid any possible cabin "hooks" on the guide rails. After that, pressing the "P" key the equipment begins to flicker for 15 seconds to permit the installer to leave the cabin totally empty.

## 4 CALIBRATION: "DIAM / LOAD"

We must choose one calibrating mode: **Automatic (DIAM)**: by the wire rope diameter, or **Manual (LOAD)**: using a known weight.

### DIAM: (DIAMETER)

Introduce the diameter in millimetres of the wire ropes. This number must be the same as the number marked on the cylinder spacers that are limiting the tightness.

### LOAD: (WEIGHT)

Place a known weight, (must be **at least, half the useful load**) inside the cabin. Introduce by means of the keys the weight in (Kg/Lb), placed inside the cabin and make the weight setting.

## 5 COMPENSATING CHAIN: "CHAI"

If our installation has a compensating chain we must select "YES".  
If our installation has not got a compensating chain we must select "NO".

**NOTE:** If we select "YES" we must be sure that the ILC3 wires (Blue) and (Blue-Red) are connected following the point 3 of the installation procedure.  
**Closed contact when door begins to close and open contact when door finishes to open.**

**Note:** Contact with a voltage range from 24 to 220 Vac/dc, during all the time lift is travelling. **Note:** Continuously.

## 6 ANALOGICAL OUTPUT: "CURR"

"NO" = We do not activate the analogical output

"4-20" = Lineal signal (4-20 mA)

"0-20" = Lineal signal (0-20 mA)

"0-24" = Lineal signal (0-24 mA)

**Note:** The analogical output provides a lineal signal.

The maximum value (20/24 mA) corresponds to the value in (Kg/Lb) of alarm 3.

### ERROR CODES:

- ERR1....No saved Data.
- ERR2...Overload.
- ERR3...Power Supply Low.
- ERR4...Negative Known weight.
- ERR5..Known weight Low/High

### SOLUTIONS:

- ERR1....Make again the settings.
- ERR2...Useful Load > 9999 Kg/Lb.
- ERR3...Check the Power Supply.
- ERR4...Some possible "Hooks" / Wrong wiring sensor.(Check the connections.)
- ERR5...See part 3 Programming procedure (Load).Place the correct useful weight

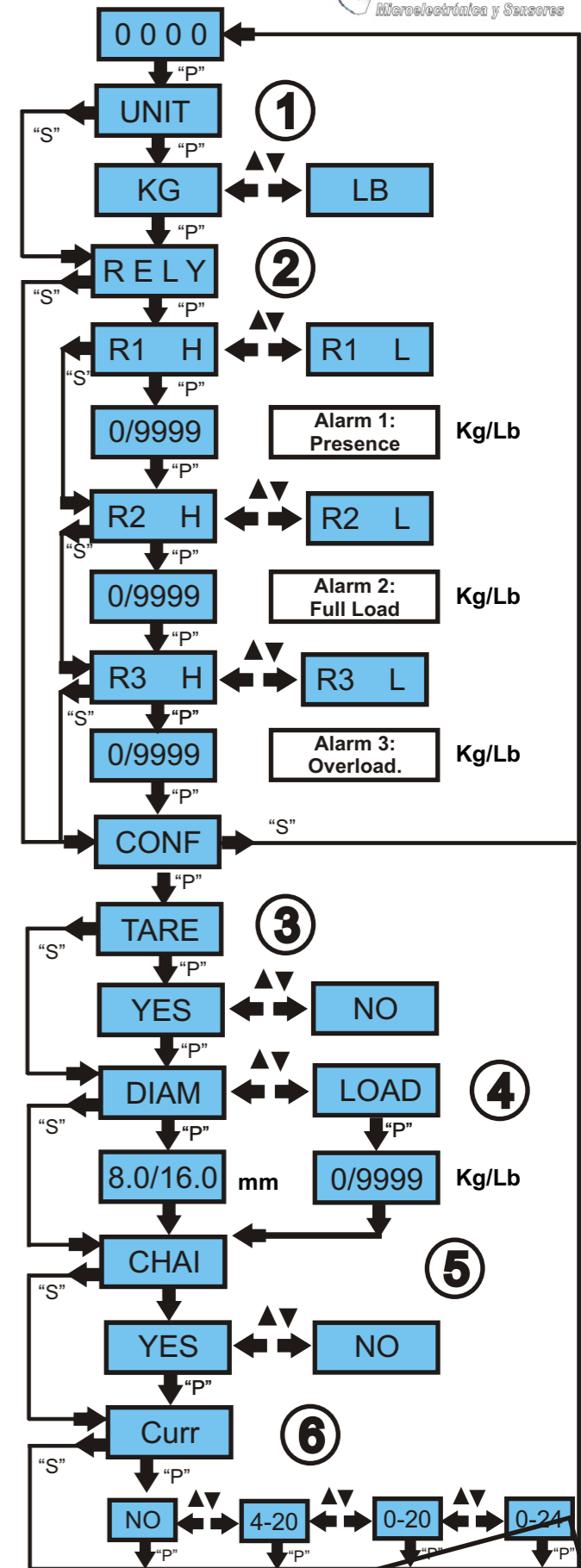

MICELECT S.L. C/OTOÑO, 23 Parque Industrial "Las Monjas" 28850 Torrejón de Ardoz MADRID (SPAIN)  
Tel: +34 91 660 03 47 Fax: +34 91 660 04 73 e-mail: [micelect@micelect.com](mailto:micelect@micelect.com) Internet: <http://www.micelect.com>

